

# Models for Phylogenetic comparative methods

and

# how to diagnose misspecified assumptions

## **Most commonly used models, continuous traits:**

- Brownian motion (BM): neutral drift
- Ornstein – Uhlenbeck (OU): selection toward optimum value

**What are their assumptions?**

**What to do with uncertain branch lengths? How do we know we use appropriate branch lengths?**

# Brownian motion (BM)

$$dY_t \approx N(0, \sigma^2 dt)$$

Neutral drift:

change in  $y$  during short time  $dt$  is not influenced by the past or by the current state ( $y_t$ )

# BM: variance increases with time

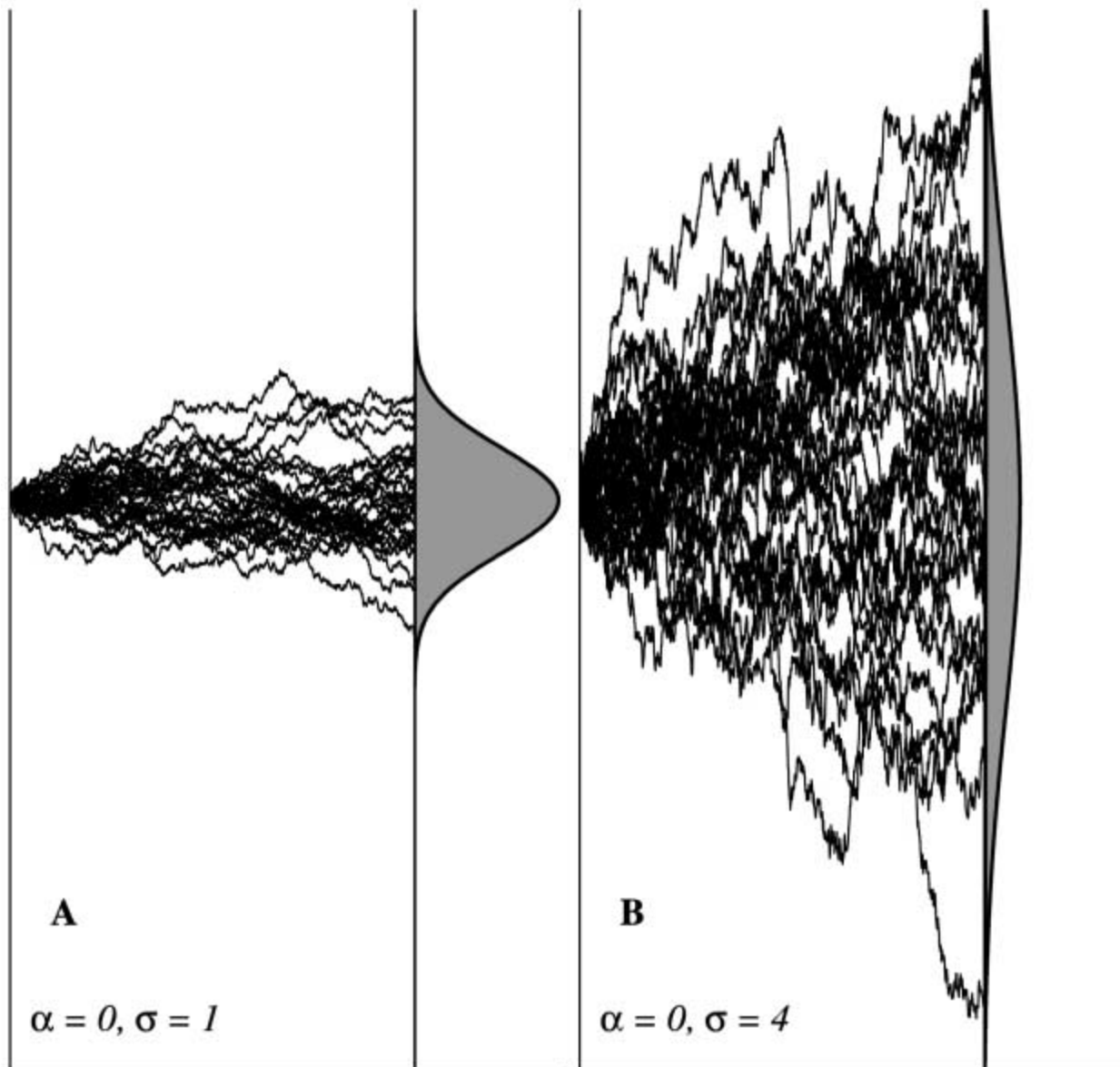

From: Butler & King,  
Am. Nat. 2004. 164: 683-695

# Ornstein-Uhlenbeck (OU) process

$$dY_t = -\alpha(Y_t - \theta) dt + dB_t$$

$\theta$  = optimum value,

$\alpha$  = selection strength,

$dB_t$  = neutral drift variation from a BM.

Selection toward  $\mu$  :

change in  $y$  is influenced by the current state ( $y_t$ ):  
trend to decrease if  $y_t > \mu$ , and to increase if  $y_t < \mu$

# Ornstein-Uhlenbeck (OU) process

Stable process: variance does not increase.

After a long time: mean  $\theta$  and variance  $\sigma^2 / 2\alpha$

$$Y_t \approx N\left(\theta, \sigma^2 / 2\alpha\right)$$

# OU: stable variance, ancestral state 'forgotten'

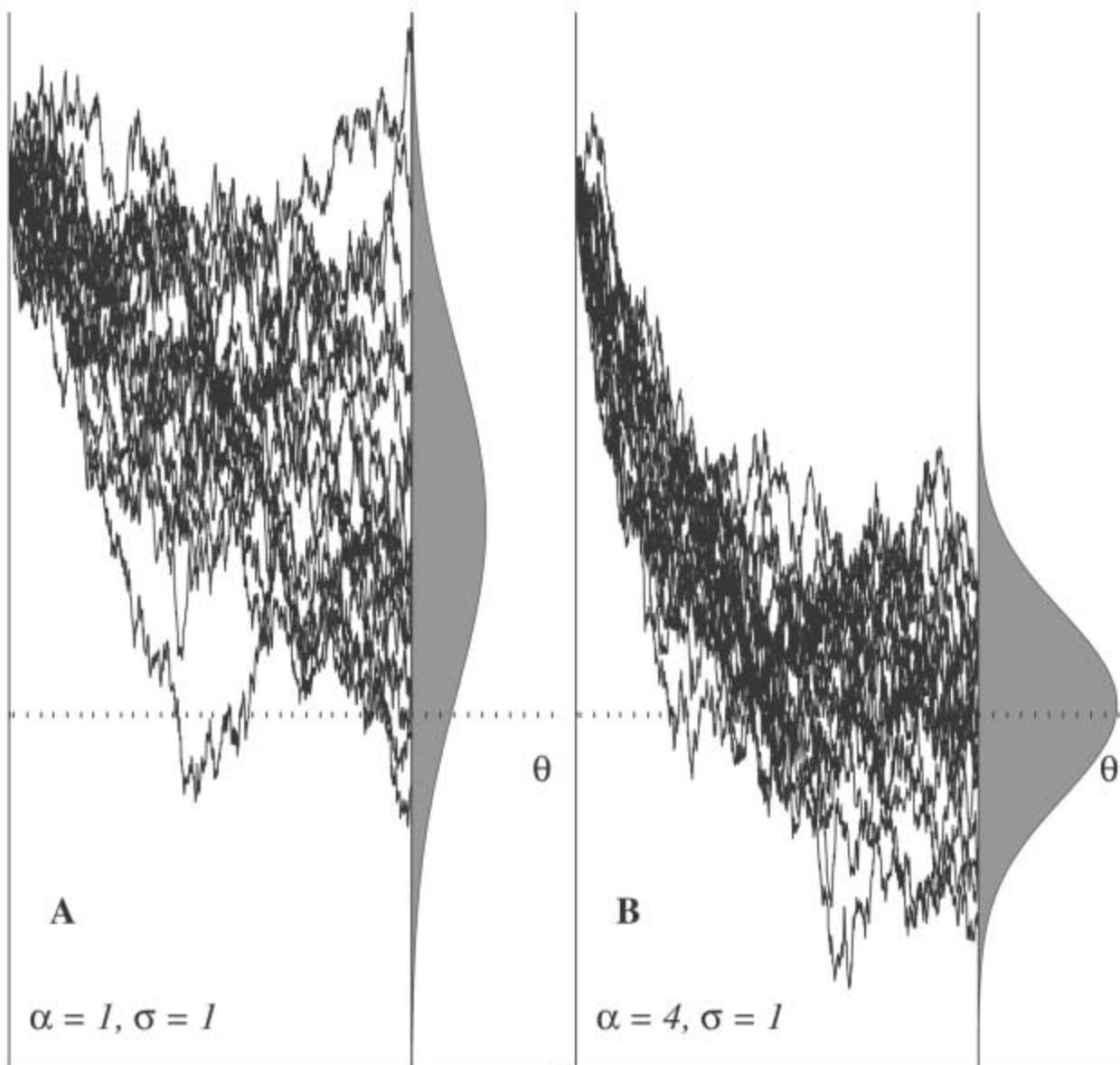

From: Butler & King,  
Am. Nat. 2004. 164: 683-695

# OU covariance matrix

If the ancestral state at the root is a model parameter:

$$V_{ij} = \frac{\sigma^2}{2\alpha} \left( 1 - e^{-2\alpha t_{ij}} \right) e^{-\alpha d_{ij}}$$

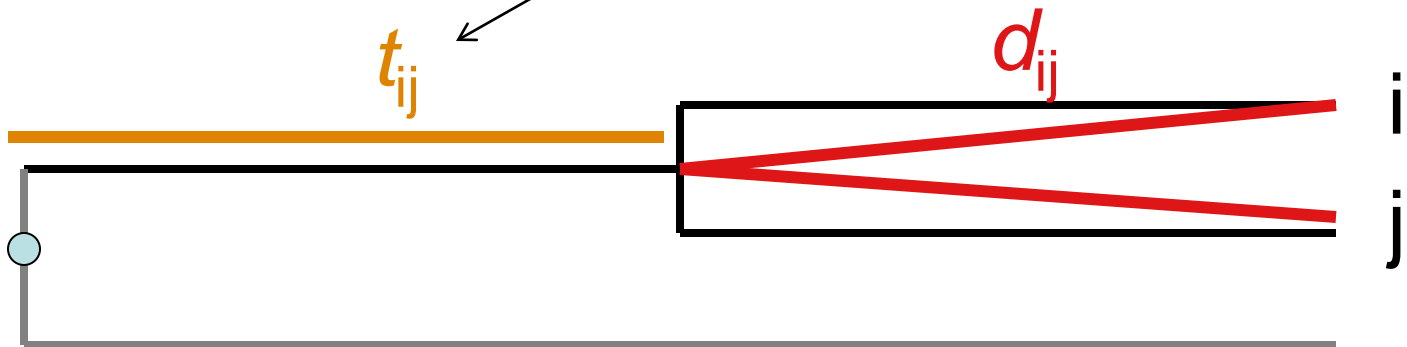



# OU covariance matrix

If the root state NOT a model parameter: assume the root has  $N(\mu, \sigma^2/(2\alpha))$ .

$$V_{ij} = \frac{\sigma^2}{2\alpha} e^{-\alpha d_{ij}}$$

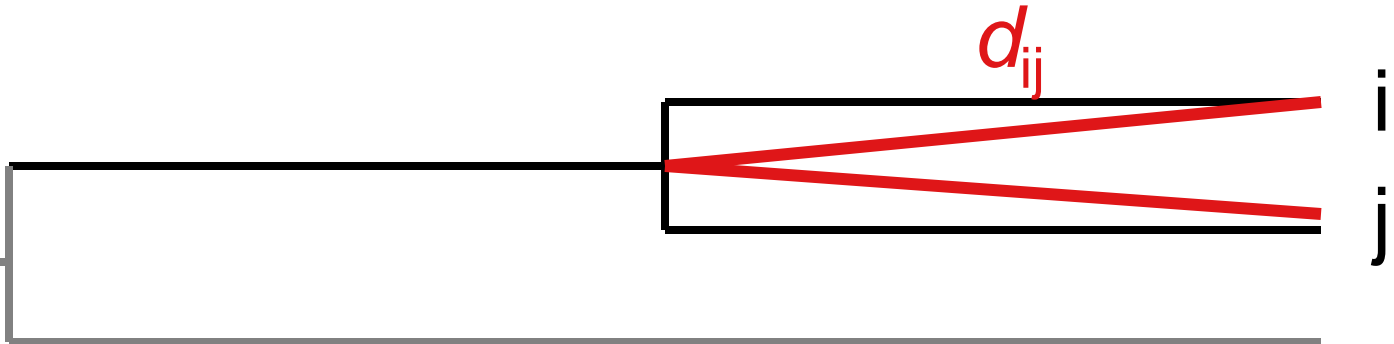

OU variance matrix is equivalent to BM on same topology but **transformed** branches ONLY if ultrametric tree.

Time, OU process ( $\alpha$ )

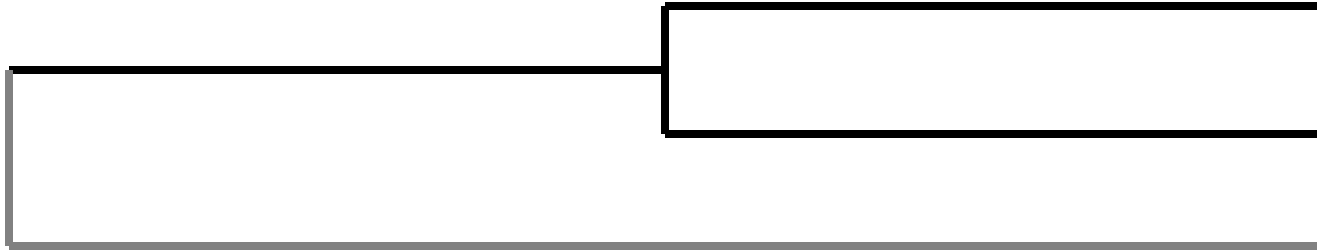

small  $\alpha$

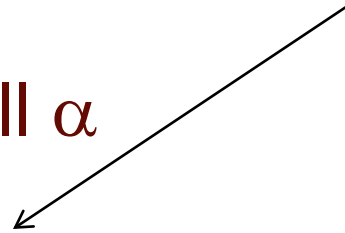

large  $\alpha$

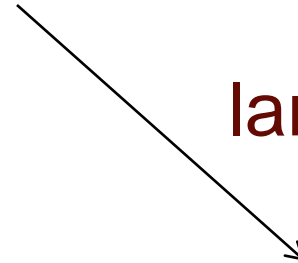

BM, variance= branch length



“The paper discussed researchers' decisions about branch lengths, especially in terms of transformations (OU, ACDC). *Do researchers use ultrametric trees for these analyses?*”

Not always, but I think that **we should prefer ultrametric** trees. Unless...

**Why:** review the package of the “BM assumption”.  
What do we really assume?

# BM: an assumption package

In a nutshell:  $Y \sim N(\mu, \sigma^2 V)$  with  $V_{ij} = t_{ij}$

This includes:

- 
- 
- 

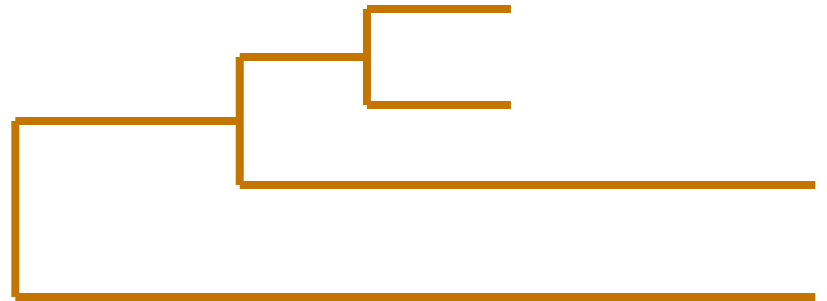
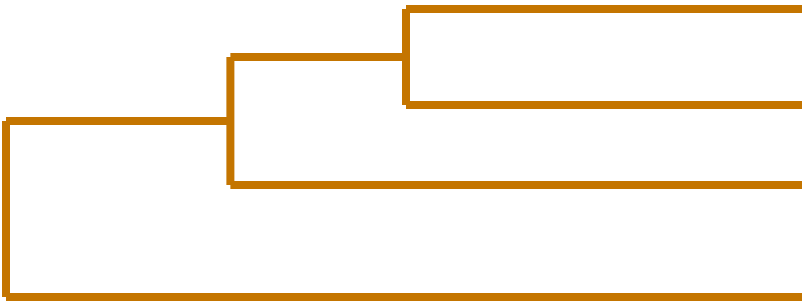

How can we **diagnose any problem** with these hypotheses?

**Normality:** usual checks for the normality of contrasts (plot)

**Constant variance** (if ultrametric tree): not usually checked.

But methods to tests if different parts of the tree have different rates.

Ex: variance smaller in one clade compared to another.

**Correct correlations:**

1. Check independence & variance homogeneity of contrasts
2. Or: use branch transformation to use the most appropriate correlation structure.

“The three main phylogenetically based statistical methods described in the reading (IC, GLS, and Monte Carlo simulations) *rely on correct information about tree topology and branch lengths*. If we are unsure of the correctness of these basic assumptions, what is the best way to analyze our data?”

Purpose of branch length transformation = meet the BM assumptions:

Correct branch lengths = correct correlation specification

# 1. Check independence & variance homogeneity of contrasts

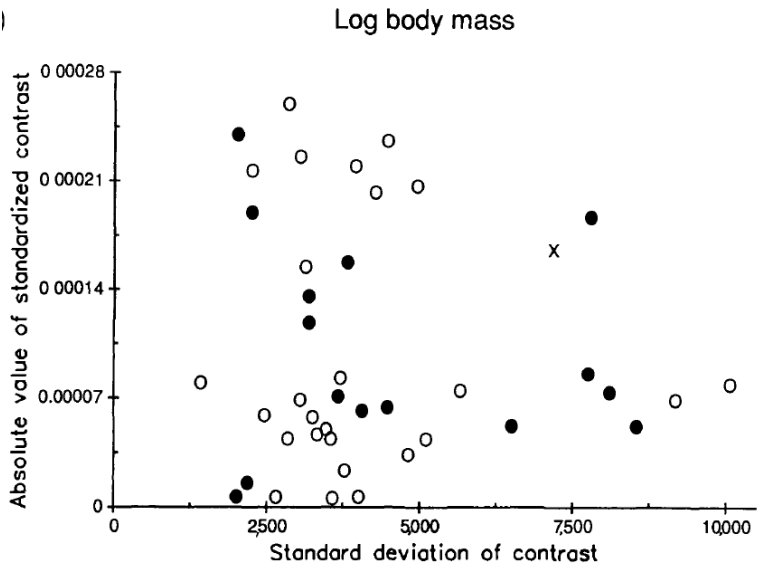

Plot contrasts (or absolute values) against:

- contrast's SD  $\sqrt{v'_i + v'_j}$
- contrast's node height

There should be no relationship, and homogeneous variance

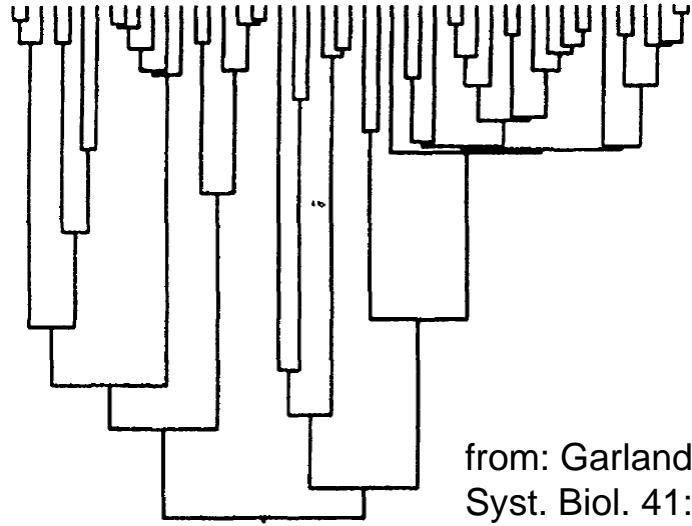
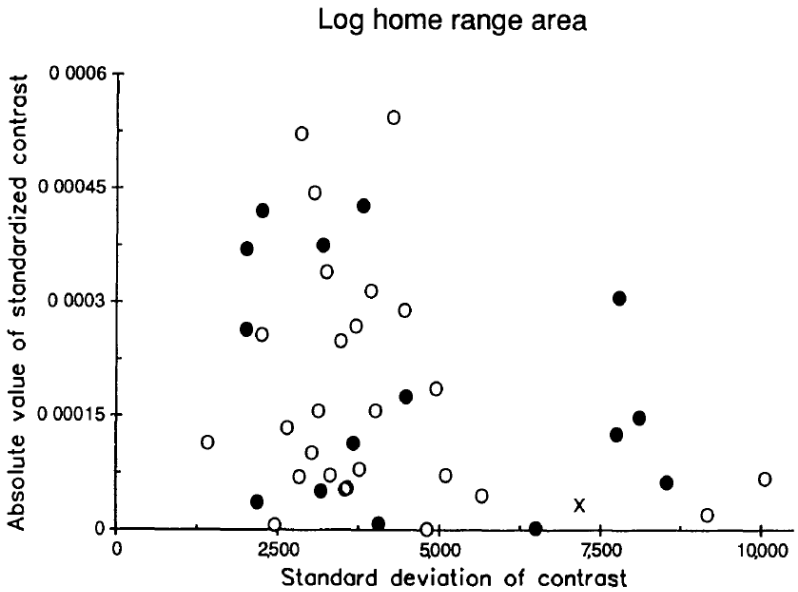

from: Garland et al (1992)  
Syst. Biol. 41:18-32

## 2. Transform branches to get most appropriate correlations

**Power transformation** ( $p=1$  for no change)

branch length  $b \longrightarrow b^p$  for some  $p>0$

or  $\log(b)$  corresponds to  $p=0$

**Grafen's rho** ( $\rho=1$  for no change)

node height  $h \longrightarrow h^\rho$  for some  $\rho>0$

**Pagel's lambda** ( $\lambda=1$  for no change)

node height  $h \longrightarrow \lambda h$  for some  $\lambda>0$

for all internal nodes. Keep original tip heights.

**OU-like alpha**, or  $d=e^{-\alpha}$  ( $d=1$  or  $\alpha=0$  for no change) but...

**Acceleration– Deceleration ACDC** ( $g=1$  for no change)

node height  $h \longrightarrow \begin{matrix} g<1 & g>1 \\ (1-g^h)/(1-g^1) \end{matrix}$  for some  $g>0$



# 2. Transform branches to get most appropriate correlations

Log home range area

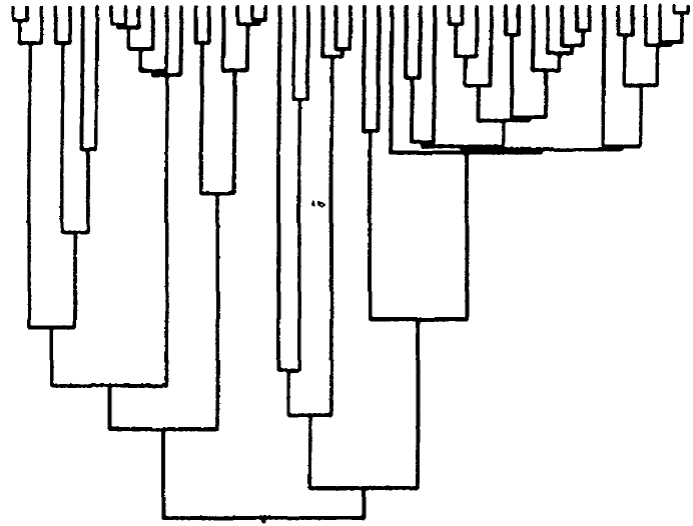
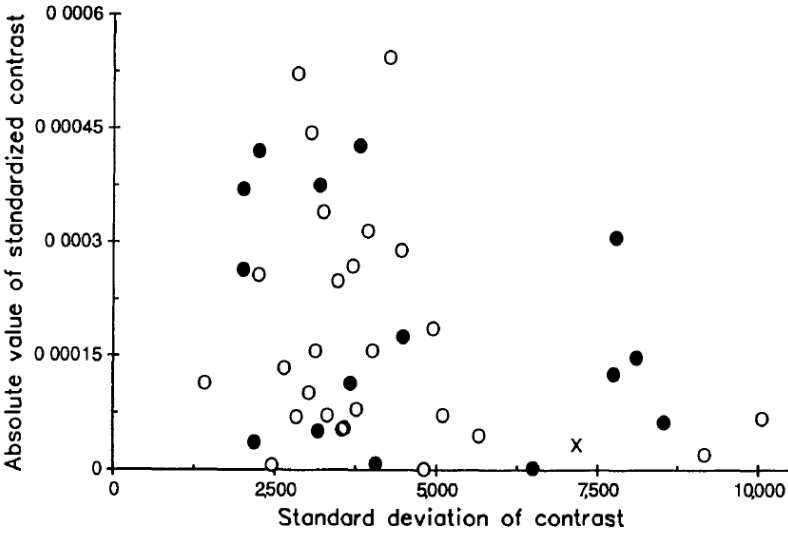

Log home range area, log branch lengths

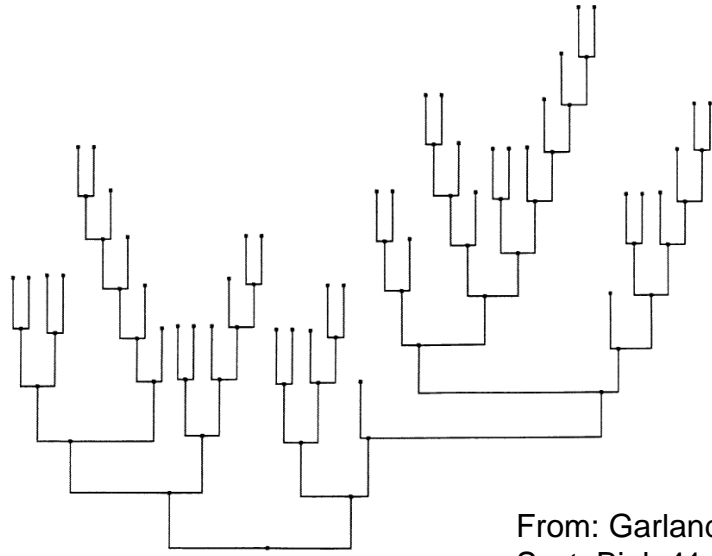
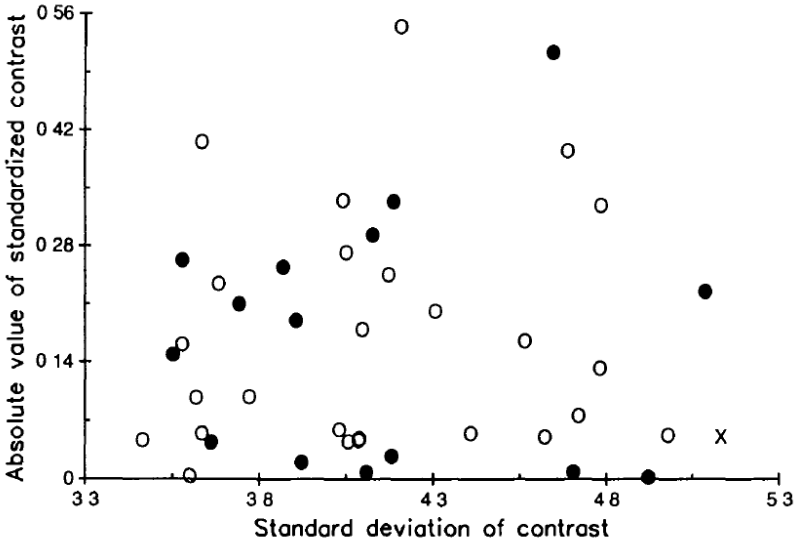

From: Garland et al (1992)  
Syst. Biol. 41:18-32

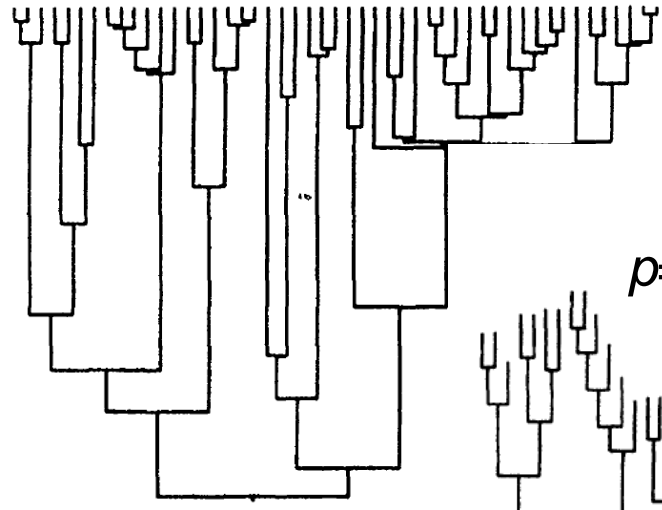

Original tree

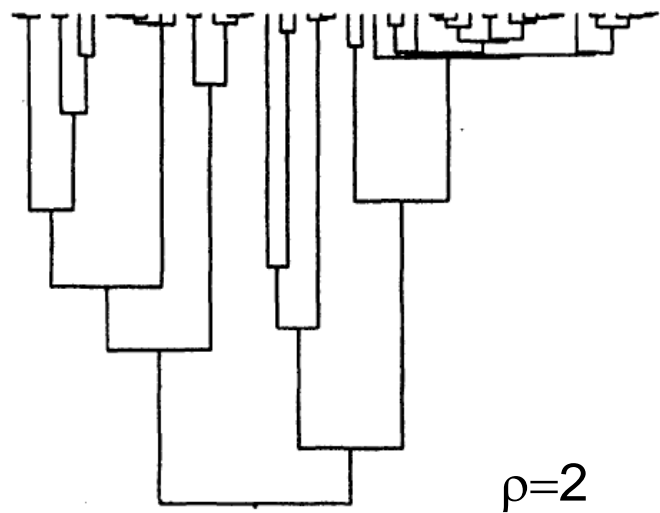
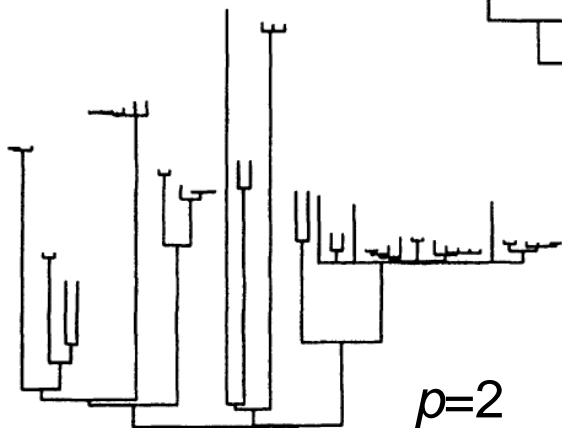
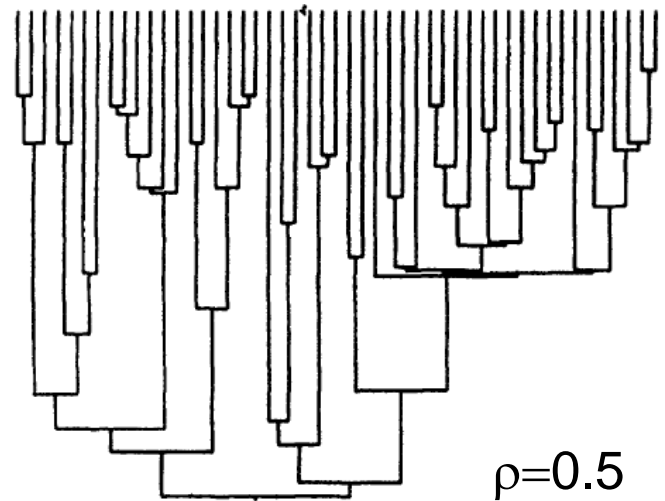
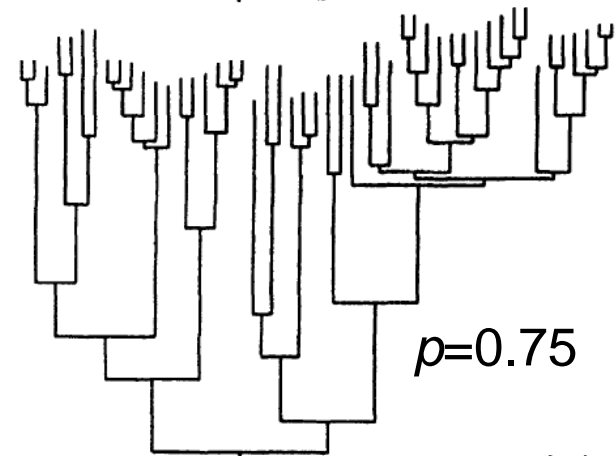
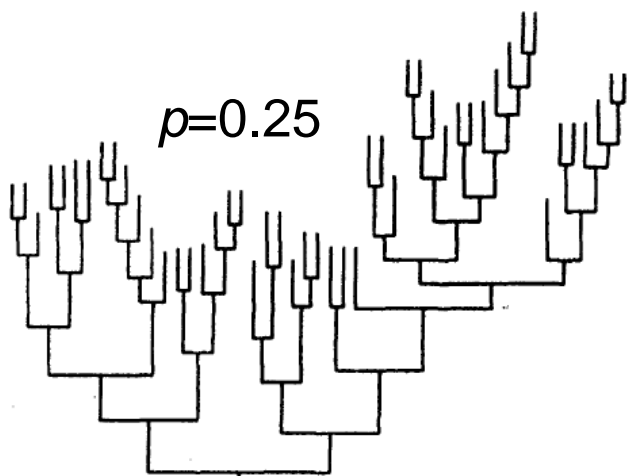

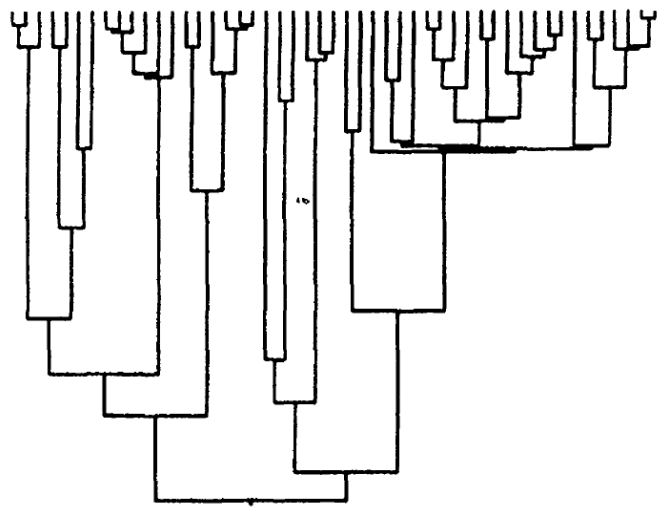

Original tree

Which transformation change

- both correlations and variances?
- correlations only?

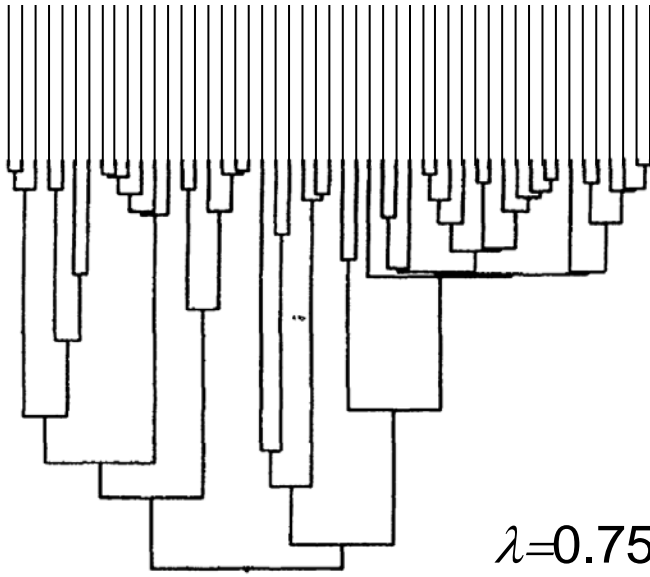

$\lambda=0.75$

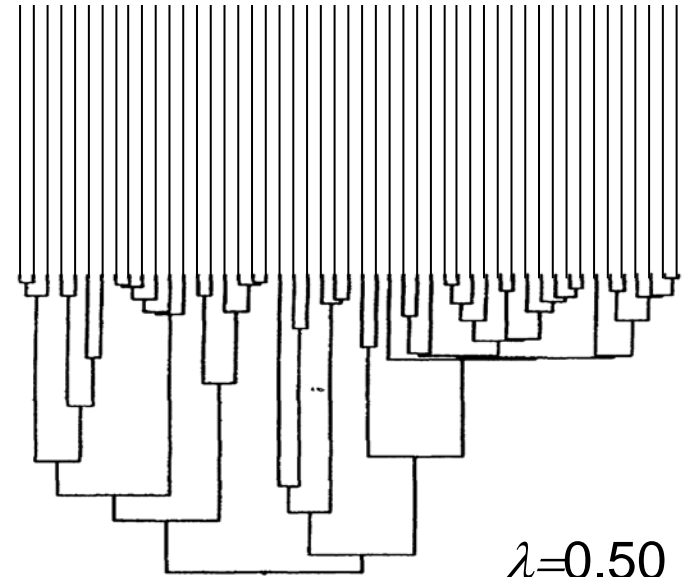

$\lambda=0.50$

## Criteria for choosing the 'best' transformation and its parameter:

- No correlation between absolute contrasts and their SD's
- No correlation between absolute contrasts and their node heights,
- Largest K value, where K measures adequacy of the correlation matrix to the data (Blomberg et al 2003):

$$K = \text{observed} \frac{\text{MSE}_0}{\text{MSE}_{\text{tree}}} / \text{expected} \frac{\text{MSE}_0}{\text{MSE}_{\text{tree}}}$$

## Caution with significance testing:

Test of  $\lambda=0$  (iid): permute species values: reassign to tips

Test of  $\lambda \neq 1$  (BM): permute contrasts values: reassign them to branches at random.

## Branch lengths transformation

It is not clear for me when I should use OU or ACDC branch length transformations?

If most of the comparative analyses assume a Brownian motion model how do I decide to use OU or ACDC branch length transformations?

I don't know anything about the rules or circumstances involved in using transformed data. I intuitively feel, if you alter the data you aren't representing the true data/signal.

The authors mention that OU and ACDC transformations work for “well-behaved evolutionary models”. But how do you approach transformations if your evolutionary model is “poorly behaved?”

The OU or ACDC transformations feel somewhat circular. Now, I'm thinking of them as tests, rather than as a means for inferring the actual timing of cladogenesis. If I'm trying to examine correlation between a trait and its underlying phylogeny, why use ideas about the evolution of the trait to transform the phylogeny? Is this a way to test if there were something like stabilizing selection on a given trait? In what kinds of subsequent analyses could I use these transformed branch lengths?

How different are these kinds of transformations (for instance, ACDC) from those that we employ for creating chronometric trees (nprs, penalized likelihood)?

## Quantification and test of phylogenetic signal

The article proposes two alternative methods to detect phylogenetic signal (randomization and branch-length transformation). If both methods give consistent results, when is it more appropriate to choose one method over another for detecting signal in a data set?

§ 3 expresses the idea that a test for phylogenetic signal can be viewed as: 1) A test for hierarchical tree structure (if BM is assumed). Or 2) A test for BM if tree topology/branch lengths are known. The latter case is less intuitive: does this test say more about the evolutionary process than the first case?

On p.734 the authors recommend a number of tests and steps for a comparative analysis. What does this say about the usefulness or validity of comparative studies before this paper or before Felsenstein's oft quoted 1985 paper?

## **Lack of phylogenetic signal from character displacement**

Character displacement results in closely related species being more dissimilar for certain traits when in sympatry than in allopatry. Could the low levels of phylogenetic signal exhibited by behavioral traits be the result of such a character displacement? The randomization tests were unable to detect any trait that showed this tendency, and if it did occur, shouldn't the test be able to detect it, regardless of the general tendency (phylogeny)? What other test could be done to detect character displacement?

## **Sample size and power of comparative studies**

Figure 2, page 721, shows the relationship of the permutation test for detecting phylogenetic signal and the number of species in the tree; showing good power with 20 or > species. Is there a need for a certain number of individuals of a species at a given tip to have good power or to make a comparative study 'valid'.